

DS9100

Wheelchair Scale

User Manual

doran[®]

Section 1. Unpacking and Installation	1
Introduction	1
Unpacking	1
Cautions and Warnings	1
Care & Cleaning	1
Moving Scale	2
Moving Ramp Location on Platform	3
Adjusting Ramp Extension Angle	3
Leveling Scale	4
Section 2. Battery Operation	5
Section 3. Scale Operation	6
Display Pushbuttons	6
Display Annunciators	7
Weighing a Patient	8
Zero Operation	8
BMI Operation	8
Last Weight Operation	8
Reweigh Operation	8
Program Wheelchair Tare Memory	9
Recall Wheelchair Tare Manually	9
Enter Tare Weight Manually	9
Clear Tare Weight	9
Section 4. Data Communications	10
Optional RS-232 Communications Port	10
Optional USB Communications Port	10
Remote Scale Commands	10
Section 5. Specifications	12
Section 6. Troubleshooting	13
General Problem Resolution	13
Error Messages	14

Section 1. Unpacking and Installation

Introduction

Thank you for purchasing a Doran scale. This product has been designed with the highest level of technology. We are dedicated to delivering a superior product that will provide many years of trouble free service.

As an ISO9000 registered company, Doran Scales is dedicated to delivering products built with strict compliance to our high quality standards. If you have any questions regarding your scale, please contact Doran Scales, Inc.

Unpacking

Carefully remove the scale from the shipping carton. If you notice any shipping damage, notify the shipper immediately. Be sure to retain all shipping materials in case the scale must be shipped elsewhere.

Cautions and Warnings

Your new scale is a durable industrial grade product, but it is also a sensitive weighing instrument. Normal care should be taken when handling and using this product. Improper handling or abuse can damage the scale and result in costly repairs that may not be covered by the warranty. Please observe the following precautions to insure years of trouble free service from your new scale.

- Do not use sharp objects to press any of the buttons.
- Do not transport patients on the scale.
- Do not use the scale if the scale is damaged in any way.
- Do not leave patients unattended on the scale.
- Do not exceed the scale capacity.
- Do not drop objects on the scale.
- Follow all instructions when moving the scale.
- When transporting, do not hit other objects, walls or doorframes with the scale.

Care & Cleaning

With reasonable care, this product will last for many years. Here are some tips to care for your scale. Failure to comply with these guidelines may void the warranty.

- Hand clean the scale platform and indicator with a moist cloth.
- Only clean with a mild detergent.
- Do not get water inside the scale platform or indicator.
- Do not use strong solvents or abrasive cleaners as this can damage the touch panel or other plastic parts.
- Do not immerse.
- Examine the scale periodically for damage and wear and tear before use.
- Remove batteries during long periods of non-use.

Moving Scale

To move the scale the tower must be folded and locked into place.

1. Fold the ramp(s) onto the scale platform.
2. Release both latches on each side of the tower.
3. Pull the tower release handle at the rear of the scale to release the tower.
4. Push the tower downwards towards the platform until you hear a click.
5. Once the tower is locked into place the scale can be tilted onto the four wheels at the rear of the platform. See Figure 1.

Once the scale is relocated, and is ready for use,

1. Place the scale platform onto the floor. See Figure 2.
2. Pull the release lever in the direction of the arrow to release the tower.
3. Pull the tower upwards. A hydraulic system will assist raising the tower.
4. When the tower locks in place, pull it towards the base to ensure it has locked into place.
5. Engage the two latches at the rear of the tower.
6. If required, unfold the ramp(s) for use.
7. Press Zero.

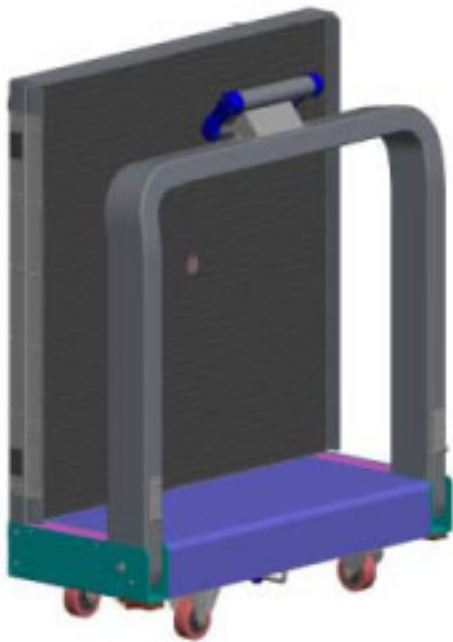

Fig. 1 Scale Ready for Transportation

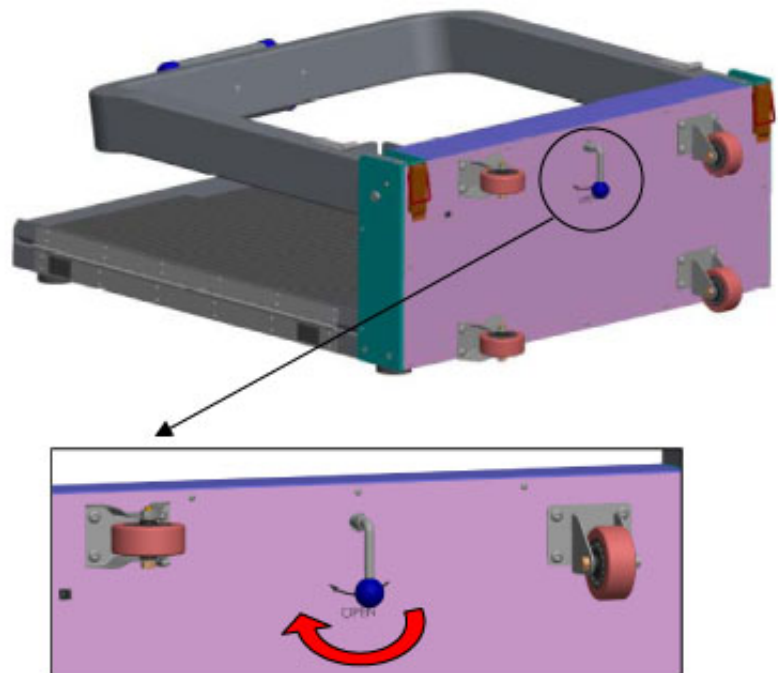

Fig. 2 Release Lever

Moving Ramp Location on Platform

If it is desired, the ramp can be installed on either side of the scale platform.

1. To remove the ramp, fold it onto the platform.
2. There are four rows of small screws. Remove the lower two rows of screws to detach the ramp.
3. Remove the wheelchair stop plate from the side directly opposite to the ramp.
4. Install the ramp to the side desired. Be sure to install all screws, washers and lock washers and tighten completely for safety.
5. Install the wheelchair stop to the side directly opposite of the ramp.

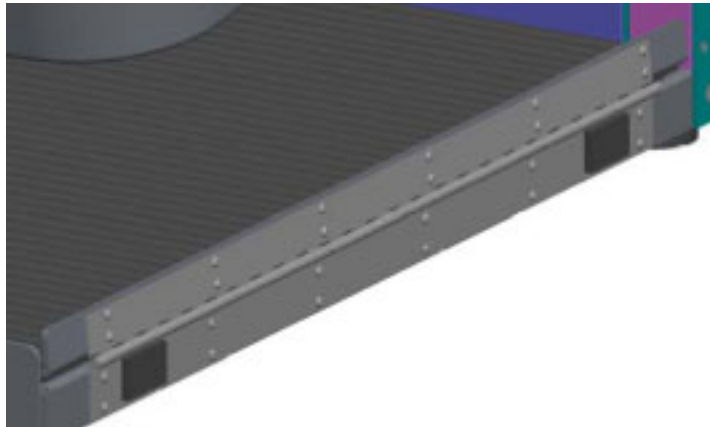

Fig. 3 Ramp Screw Configuration

Adjusting Ramp Extension Angle

The ramp is designed to not touch the floor when weight is not applied to the ramp. This feature increases scale accuracy and repeatability. If required, the angle of the ramp when extended can be changed.

1. Extend the ramp from the platform.
2. If the ramp is contacting the ground, an adjustment is required.
3. Fold the ramp onto the platform.
4. Five large screws control the angle of the ramp when extended.
5. Adjust the screws outward to raise the ramp or adjust inward to lower the ramp when extended.
6. Extend the ramp and confirm the ramp is no longer touching the ground. Up to a 1/8" gap is acceptable.

Leveling Scale

If the scale is to be used in a permanent location, it is recommended to level the scale. Leveling the scale will provide a stable weighing surface and optimal accuracy. To level the platform, use the end of the flat wrench marked with an 'F' provided with the scale. Insert the wrench into place and twist the foot to change the height while grasping the wrench.

After leveling the scale, press Zero.

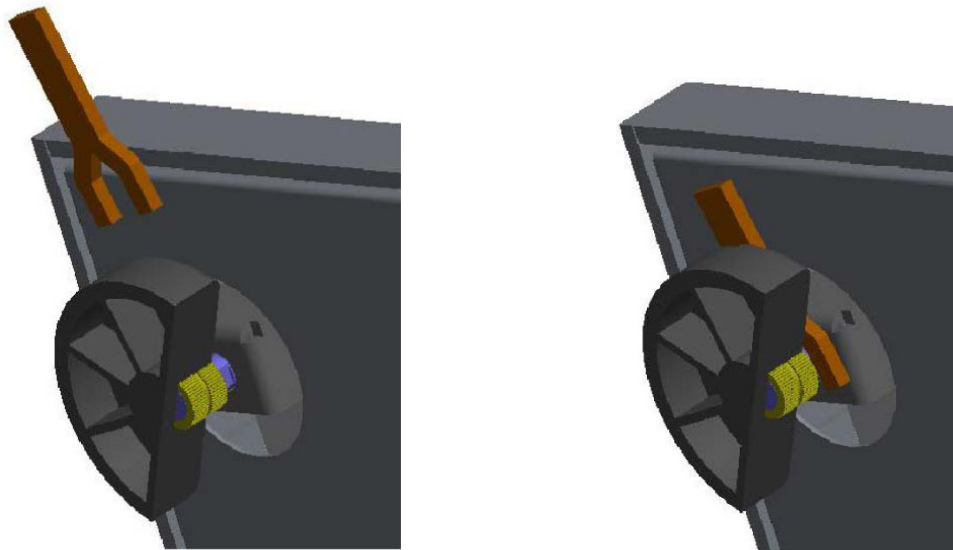

Section 2. Battery Operation

Battery Installation

The DS9100 comes with a set of six AA alkaline batteries. These batteries supply two years of typical use with the standard Automatic Shutoff Timer settings. Most customers will find that the outstanding battery life provides a good solution for permanent installations as well.

The batteries can be accessed on the lower right hand side of the indicator. To remove the battery tray, use a Phillips screwdriver to remove the screw holding the battery compartment in place. Completely remove the battery compartment from the indicator and install the new set of batteries. Be sure the batteries are oriented properly.

When reinstalling the battery tray, mate the key at the bottom of the battery tray to the key integral to the metal housing. Gently push and hold the battery tray in place and reinstall the screw to complete the battery tray installation.

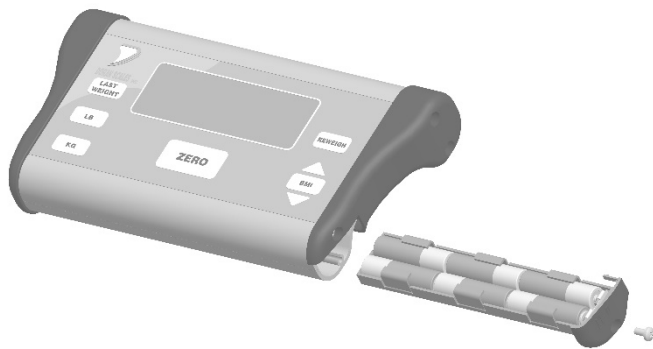

Fig. 4 Battery Tray Access

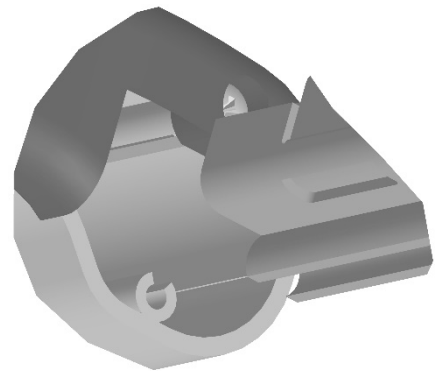

Fig. 5 Battery Tray Insertion

Battery Indicator

The battery indicator displays the remaining battery life available. A low battery status is also indicated by two beeps when a weight is held.



Replace Batteries



Maximum Battery

Section 3. Scale Operation

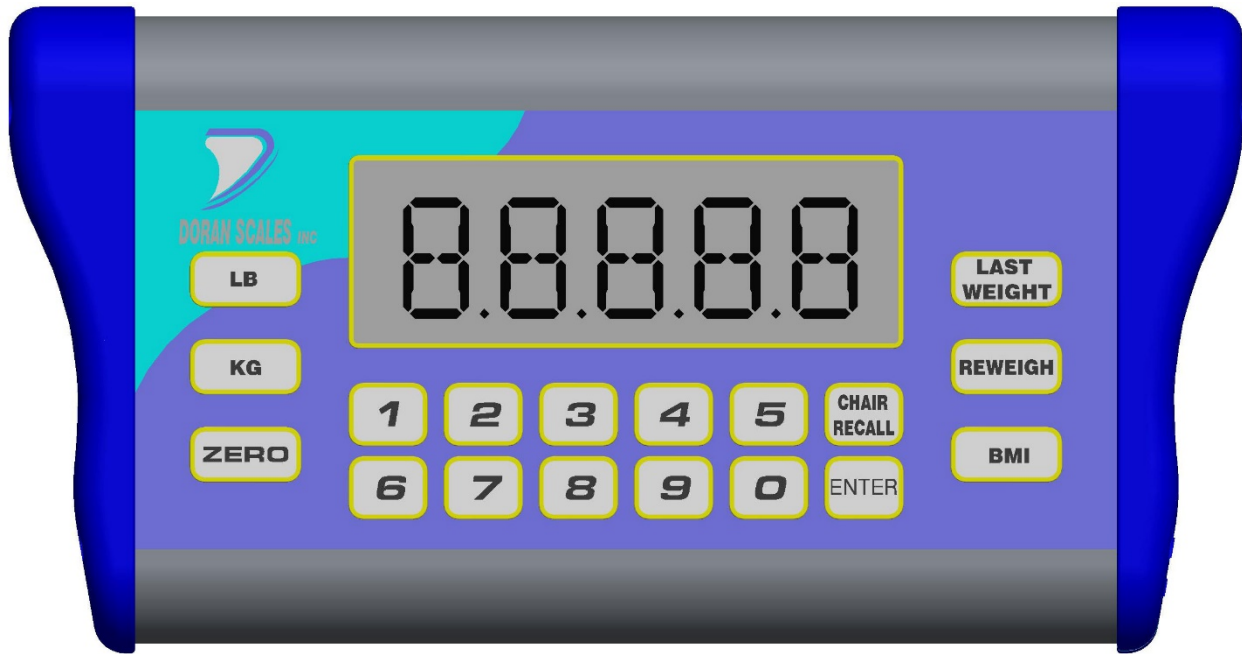

Fig. 6 DS9100 Front Panel

Display Pushbuttons

The Model DS9100 controls consist of LAST WEIGHT, LB, KG, ZERO, REWEIGH, BMI, CHAIR RECALL, ENTER and a numeric keypad. The display is used to provide weight indications and operator messages indicating scale operation.

Power On/Off

When the patient stands on the scale platform, the indicator will turn on automatically. The indicator has an adjustable Automatic Shutoff Timer that will power down the indicator when not in use.

Zero

When the zero button is pressed, the scale will be reset to zero weight. This feature can be used to zero out any weight not desired to be part of the patient weight.

Units Select

Press LB to weigh in pounds and enter BMI height in feet and inches. Press KG to weigh in kilograms and enter BMI height in centimeters. The current unit will be displayed to the right of the weight digits.

Reweigh

To reinitiate the weighing process, press REWEIGH. This will allow a weighment to be reinitiated without the patient having to get off the scale platform.

BMI

Once a weight is held, the height of the patient can be entered using the full keypad by pressing the BMI button.

Display Annunciators

Motion

When the scale platform senses motion, MOTION will be indicated. Once motion ceases, a stable hold reading will be displayed.

Center of Zero (→0←)

Indicates that the scale has an accurate zero reading.

Stable Hold

Indicates a stable weight has been achieved and held on the display. This indicates an accurate weight has been achieved.

Average Hold

Indicates that the weight held on the display is a result of averaging several weights due to excessive motion on the scale platform. The Average Hold weight may be slightly less accurate than a Stable Hold weight.

Displaying an Average Hold weight instead of a Stable Hold weight will speed the weighment process of patients that cannot stand still. The Average Hold weight will differ from the patient's actual weight based upon the severity of the motion caused by the patient while on the scale. Although this weight may be less accurate than a Stable Hold weight, the deviation from the patient's actual weight will be minimal.

The time required for the Average Hold to engage is based upon the Average Aperture parameter. See the Parameter Setup section for configuration instructions.

Last Weight

Last Weight is indicates when a previous weight is being displayed.

Battery Indicator

The battery indicator displays the remaining battery life available. See battery operation section for detailed information.

NET

Indicates a net weight is displayed when a tare weight is active.

Weighing a Patient

1. Move the patient onto the scale platform.
NOTE: The indicator tower can be grasped during weighing.
2. The indicator will automatically turn on and display weight.
3. The indicator will beep and hold the weight on the display until the scale shuts off automatically.

Zero Operation

1. Place item to be zeroed out on the scale platform.
2. Press ZERO. The scale will turn on and display a zero weight. If the item is removed, a negative weight will be displayed.
Note: If the scale display automatically shuts off, the new zero point will be saved.
3. Move the patient onto the scale platform and the patient's weight, less the item's weight will be displayed.
4. To reset the scale to zero, Press ZERO again with the scale platform empty.
Note: If the scale zero is not reset with an empty platform, the zero weight will be retained in memory and cause weighing errors for future patients.

BMI Operation

1. Move the patient onto the scale platform.
2. The display will beep when a stable or average hold weight is achieved.
3. Press BMI. The display will read 5:06, representing 5 feet, 6 inches.
4. Enter the patient's height using the full keypad.
NOTE: if the patient's height is 6 foot 1 inch. Press 6 – 0 – 1 and the BMI value will be displayed.
5. The BMI value will be displayed.

Last Weight Operation

1. Press LAST WEIGHT to display the previously held stable or average hold weight.
2. To display the previous BMI value, press BMI and the previous height is displayed.
NOTE: If the height needs to be changed, press ENTER.
3. Press BMI again and the BMI value will be displayed.

Reweigh Operation

1. With the patient on the scale platform, press REWEIGH to reinitiate the weighing process.

Program Wheelchair Tare Memory

1. Press tare memory location to be changed (0 through 9)
2. Press CHAIR RECALL. The current tare value in memory will be displayed.
3. Press ENTER to change the tare value in memory.
4. Enter the tare value to be saved. Enter zero for any digit that is not required. (For example: To enter a tare value of 41.1 LB, press 0-4-1-1)
5. Press ENTER.

NOTE: A tare weight can be recalled when the scale is off or while a patient is on the scale. Recalling a tare value will initiate a reweigh function.

Recall Wheelchair Tare Manually

1. Press CHAIR RECALL.
2. Press memory location to be recalled. (For Example: press key 1 to recall memory location 1)

Enter Tare Weight Manually

1. Enter the tare weight using the numeric keypad.
2. Press ENTER.

NOTE: A tare weight can be entered when the scale is off or while a patient is on the scale. Entering a new tare value will initiate a reweigh function.

Clear Tare Weight

By default, tare weights are stored in memory until cleared. Be sure to clear any unwanted tare weights after using the scale.

1. Press ZERO to clear a stored tare weight

NOTE: See the ATC parameter in Section 5 to auto clear the tare value when the scale turns off.

Section 4. Data Communications

Optional RS-232 Communications Port

The DS6100 can be equipped with an optional RS-232 communications port. If this option has been installed, the RS-232 connection is located on the left side of the indicator housing. An RS-232 cable is included with the option. Insert the headphone jack style connector into the receptacle on the indicator housing and connect the 9-pin connector to your computer or printer.

Note: This option will reduce battery life.

Basic understanding of RS-232 data communications is needed when setting up the DS6100 to communicate with a printer or PC. When setting up an RS-232 communications system, there are two concerns which affect the configuration of that system. These are:

- Baud Rate
- Data Bits and Parity

The baud rate determines how fast the data is sent from the scale. The sending and receiving units must be set to the same baud settings. The typical value is 9600.

The DS6100 is factory set for eight bits, no parity and one stop bit also known as 8n1. The receiving units must be set to 8n1 for proper communications.

Optional USB Communications Port

The DS9100 can be equipped with an optional USB communications port. If this option has been installed, the USB connection is located on the left side of the indicator housing. A USB cable is included with the option. Follow the instructions included with the option to install all necessary drivers.

Once the USB driver is installed on your PC, insert the USB connector into the receptacle on the indicator housing and connect the other end of the cable to your computer.

Remote Scale Commands

The scale will respond to the following single letter ASCII commands.

- | | |
|---|--|
| W | Initiates transmission of current weight data (if in motion, scale will wait until stable, then print) |
| U | Changes the displayed weight units. |
| Z | Zeroes the scale (if in motion, scale will wait until stable, then zero) |

“F0” Example

☉ 150.2 lb ␣

Print String Definition for Each Weight Unit:

Pounds

STX | POL | WEIGHT | SP | lb | SP | CR | LF

Kilograms

STX | POL | WEIGHT | SP | kg | SP | CR | LF

“F1” Example

☉ 198.6#lb#GRS# 0.0#lb# 69.5#in# 27.1#BMI␣

Print String Definition for Each Weight Unit:

Pounds

STX | POL | WEIGHT | # | lb | # | GRS | # | TAREVALUE | # | lb | # | HEIGHTVALUE | # | in | # | BMIVALUE | # | BMI | CR | LF

Kilograms

STX | POL | WEIGHT | # | kg | # | GRS | # | TAREVALUE | # | kg | # | HEIGHTVALUE | # | cm | # | BMIVALUE | # | BMI | CR | LF

Data String Key

STX (☉) = ASCII 02, non printable character

POL = minus sign for negative weight or a space for a positive weight

WEIGHT = 6 character field

TAREVALUE = 6 character field

HEIGHTVALUE = 6 character field

BMIVALUE = 5 character field

SP = ASCII space

CR (␣) = Carriage return, non printable character

LF (␣) = Linefeed, non printable character

| = Separator for reference, not printed

Section 5. Specifications

Scale Platform Dimensions	32.5" L x 33" W x 3" H
Scale Dimensions with Ramp Folded	42" L x 33.5" W x 45.5" H
Scale Dimensions with Ramp Extended	42" L x 49" W x 45.5" H
Scale Dimensions with Second Ramp option, Both Ramps Fully Extended	42" L x 64.5" W x 45.5" H
Wheels	Permanently sealed and lubricated Wheel Material EVA
Power	6 AA Alkaline Batteries Two year battery life with 10 second Automatic Shutoff Timer setting
Displayed Units	lb, kg
Capacity	1000 x 0.1 lb 454 x 0.05 kg
Construction	Painted Mild Steel Base and Column Aluminum Indicator with Plastic End Caps
Approvals	CE 2006/95/EC Low Voltage Directive Reference Standard: CENELEC EN 61010-1 2004/108/EC EMC Directive Reference Standard: CENELEC EN 61326
Options	RS-232 Communications USB Communications Second Ramp AC Adapter

Section 6. Troubleshooting

General Problem Resolution

Problem	What to Do or Check
Weight reading will not repeat or scale does not return to zero when weight is removed.	<p>If on carpet, verify the bottom of the platter is not touching the carpet.</p> <p>Person or object other than that being weighed is touching the scale.</p> <p>Verify that there is nothing caught in the platform or interfering with the feet.</p>
Scale overloads before scale capacity is reached.	Verify scale calibration is correct. If problem persists, recalibrate the scale.
Scale will not come to zero when the ZERO button is pressed.	Make sure that the scale is stabilizing (Motion annunciator is off). After pressing the ZERO button, the scale should zero as soon as it becomes stable.
Weight readings are not correct.	<p>Verify the scale calibration with an accurate test weight. If the readings are not correct, recalibrate.</p> <p>Be sure the platform is on a flat surface and all four feet are touching the floor.</p>
Scale drifts off zero.	Check for air currents and/or vibration around the scale.
Scale shuts itself off or will not turn on.	<p>Press the ZERO button to turn on the indicator.</p> <p>Check that new batteries are installed properly in the battery tray.</p> <p>If using an AC adapter, confirm that it is firmly plugged into a functioning wall outlet.</p> <p>Verify the connector at the rear of the indicator is properly installed.</p>

Error Messages

Error Message	What to Do or Check
Er EP	<p>The setup parameters loaded in nonvolatile memory have become corrupted.</p> <p>Reset all parameter to factory default with the rst parameter.</p>
Er Ad	<p>The A/D communication is not detected. Ensure the cable is connected to the rear of the indicator.</p> <p>If problem persists, internal connectors will need to be checked. Contact Doran Technical Support for assistance.</p>
Err 0	<p>The calibration zero is out of range. This error is displayed after a zero calibration attempt. Remove all weight from the platform and press BMI to perform the zero calibration again.</p> <p>Refer to the Calibration Troubleshooting section for additional information. If this problem persists, contact Doran Technical Support for assistance.</p>
Errsp	<p>The span calibration is out of range. This error is displayed after a span calibration attempt. Place the proper weight on the platform and press BMI to perform the span calibration again.</p> <p>Refer to the Calibration Troubleshooting section for additional information. If this problem persists, contact Doran Technical Support for assistance.</p>
ou ld	<p>The scale is in overload. The load on the scale platform exceeds the scale capacity by more than 105%.</p> <p>Remove excess weight from scale platform. If problem persists, recalibrate. If this problem persists, contact Doran Technical Support for assistance.</p>
Gs ol	<p>The scale is in an extreme overload condition. The load on the scale platform exceeds the scale capacity by more than 150%.</p> <p>Immediately remove excess weight from scale platform as damage can occur. If this problem persists, recalibrate. If this problem still persists, contact Doran Technical Support for assistance.</p>

**Doran Scales, Inc.
883 Enterprise Court
St. Charles, IL 60174**

www.doranscales.com

630-879-1200