

DS4500

Infant Lactation Scale

Technical Manual

doran[®]

MAN0348 – Rev 2

Doran Scales, Inc.

www.doranscales.com

Section 1. Unpacking and Care	1
Unpacking	1
Cautions and Warnings	1
Care & Cleaning	1
Preventive Maintenance	1
Installation	2
Battery Installation	2
Section 2. Scale Operation	3
Display Pushbuttons	3
Display Annunciators	4
Weighing a Patient	5
Zero Operation	5
Reweigh Operation	5
Feed Function	6
Section 3. Scale Calibration	8
Two Point Calibration Procedure	8
Multiple Point Calibration	9
Calibration Troubleshooting	10
Section 4. Parameter Setup	11
Entering and Exiting Setup Mode	11
Setup Mode Navigation	11
Calibration Weight Selection	11
Calibration Mode Selections	11
Start Up Zero	12
Automatic Shutoff Timer	12
LB Units Enable / Disable	12
lb:oz Units Enable / Disable	12
KG Units Enable / Disable	12
OZ Units Enable / Disable	12
Grams Units Enable / Disable	12
Raw Counts	13
Section 5. Data Communications	14
Section 6. Specifications	15
Section 7. Troubleshooting	16
General Problem Resolution	16
Error Messages	17

Section 1. Unpacking and Care

Thank you for purchasing a Doran scale. This product has been designed with the highest level of technology. We are dedicated to delivering a superior product that will provide many years of trouble free service.

As an ISO9001 registered company, Doran Scales is dedicated to delivering products built with strict compliance to our high quality standards. If you have any questions regarding your scale, please contact Doran Scales, Inc.

Unpacking

Carefully remove the scale from the shipping carton. If you notice any shipping damage, notify the shipper immediately. Be sure to retain all shipping materials in case the scale must be shipped elsewhere.

Cautions and Warnings

Normal care should be taken when handling and using this product. Improper handling or abuse can damage the scale and result in costly repairs that may not be covered by the warranty. Please observe the following precautions to ensure years of trouble free service from your new scale.

- Do not use sharp objects to press any of the buttons.
- Do not pick up the scale by the indicator or cables.
- Do not use the scale if it is damaged in any way.
- Do not leave patients unattended on the scale.
- Do not exceed the scale capacity.
- Do not drop the scale.
- Do not drop objects on the scale.
- When transporting, do not hit other objects, walls or doorframes with the scale.

Care & Cleaning

With reasonable care, this product will last for many years. Here are some tips to care for your scale. Failure to comply with these guidelines may void the warranty.

- This scale will withstand typical cleaning methods and chemicals that are used in healthcare environments. This includes but not limited to cleaners that contain sodium hypochlorite (bleach), hydrogen peroxide and alcohol.
- Do not get water inside the indicator or platform.
- Do not immerse in water or any liquid.
- Do not use strong solvents or abrasive cleaners as this can damage the touch panel or other plastic parts.

Preventive Maintenance

- Examine the scale periodically for damage and wear and tear before use.
- If the scale is damaged, check calibration of the scale and safety before use.
- Check calibration annually and calibrate if necessary.
- Remove batteries during long periods of non-use.

Installation

Place the scale on a stable flat surface. The scale should rest evenly on all four feet.

Battery Installation

The DS4500 comes with the ability to take four AA alkaline batteries. These batteries supply a year's of typical use with the standard Automatic Shutoff Timer settings. The standard Automatic Shutoff Timer setting is one minute.

The batteries can be accessed on the bottom of the scale. To access the battery compartment, turn the scale upside down and open the battery compartment door. When installing the new set of batteries, be sure the batteries are oriented properly.

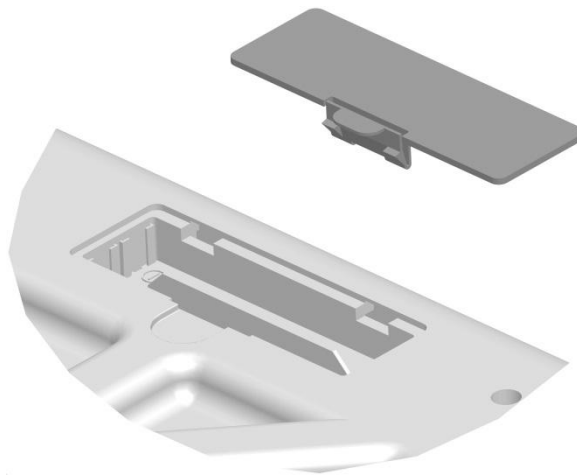

Fig. 1 Battery Door

Section 2. Scale Operation



Fig. 2 DS4500 Front Panel

Display Pushbuttons

The Model DS4500 controls consist of FEED, UNIT, REWEIGH, POWER and ZERO buttons. The display is used to provide weight indications and operator messages indicating scale operation.

Power On/Off

Press the Power button to turn on and off the scale. The scale has an adjustable Automatic Shutoff Timer that will power down the scale when not in use.

Zero

When the zero button is pressed, the scale will be reset to zero weight. This feature can be used to zero out any weight not desired to be part of the patient weight.

Unit

Press to cycle between any active unit lb, lb:oz, oz, kg or g. The current unit will be displayed to the right of the weight digits.

Note: Each unit can be disabled individually with the units enable / disable parameters. Only lb:oz and kg are enabled by default.

Reweigh

To reinitiate the weighing process, press REWEIGH. This will allow a weightment to be reinitiated without the patient having to get off the scale platform.

Feed

Activates the feed function. See feed function section below.

Display Annunciators

The display annunciators will indicate the scale status.

Center of Zero (► 0 ◀)

Indicates that the scale has an accurate zero reading.

Hold

Indicates a stable weight has been achieved and held on the display. This indicates an accurate weight has been achieved.

Low Batt

Indicates when the batteries require replacement.

BEFORE FEED

Indicates the next held weight recorded will be recorded for BEFORE FEED data string.

AFTER FEED

Indicates the next held weight recorded will be recorded for AFTER FEED data string.

AMOUNT FED

Indicates the amount of food the baby has retained is displayed and transmitted.

Weighing a Patient

1. Press On/Off. The scale will turn on and display a zero weight.
2. Place patient on the scale.
3. When a stable weight is reached the display will lock and the HOLD annunciator will be displayed.
4. The weight will be locked until the scale shuts off.

Zero Operation

1. With the scale off, place item to be zeroed out on the scale platform.
2. Press On/Off. The scale will turn on and display a zero weight. If the item is removed, a negative weight will be displayed.
Note: Each time the scale is powered up, the zero point is reset.
3. Place the patient on the scale and the patient's weight, less the item's weight will be displayed.

OR

1. With the scale on, press ZERO.
2. The display will display dashes.
3. When scale becomes stable, the display will read zero.

Reweigh Operation

With the patient on the scale platform, press REWEIGH to reinitiate the weighing process.

Feed Function

Accurately measuring infant milk intake during breastfeeding is important in the management of infants, as well as in addressing breastfeeding concerns with healthy infants at home.



The DS4500 allows for a single total fed weight and a left / right with total fed process. Once the amount fed process is started, the automatic shutoff timer is deactivated to prevent lost weightments. The operator must turn off the scale manually after the process is completed.

Instructions for Weighing Single Total Fed Weight

1. Turn on scale
2. Press Feed
3. Place infant on the scale
4. Display reads infant weight and BEFORE FEED annunciator is activated
5. Remove the infant from the scale and feed the infant
6. Place infant on the scale
7. Total infant weight is displayed and AFTER FED annunciator is activated
8. Press Feed – the total fed weight is displayed and AMOUNT FED annunciator is activated
9. Operator must press on/off to turn off scale after weights are recorded.

Instructions for Weighing Individual Left / Right Feed Weights

1. Turn on scale
2. Press Feed
3. Place infant on the scale
4. Display reads infant weight and BEFORE FEED annunciator is activated
5. Remove the infant from the scale and feed the infant
6. Place infant on the scale
7. Total infant weight is displayed and AFTER FED annunciator is activated
8. Press Feed – the first side weight is displayed and AMOUNT FED annunciator is activated. The amount fed weight is held on display until step 10.
9. Remove infant from the scale and feed the infant
10. Place infant on the scale
11. Total infant weight is displayed and AFTER FED annunciator is activated
12. Press Feed – the second side weight is displayed and AMOUNT FED annunciator is activated.
13. To review first side, second side and total fed weights, press Feed to cycle through the first, second and total amount fed. The left display digit will indicate the weight shown per the table below.

Displayed Weight	Left Digit
First Side Weight	
Second Side Weight	
Total Fed Weight	

14. Operator must press on/off to turn off scale after weights are recorded

Section 3. Scale Calibration

Two Point Calibration Procedure

This calibration procedure is intended to be used when a full set of calibrated weights are not available. When possible, use the multiple point calibration procedure below. *CAUTION: Calibrating this scale improperly will void the warranty and will require field service or return of the scale to the factory.*

1. Turn the scale on by pressing the ON/OFF button.
2. Press and hold ZERO and REWEIGH simultaneously.
3. When the display reads $\overline{\text{CAL}} .45$ lb, release ZERO and REWEIGH.
4. If desired, press FEED to use a span calibration of $\overline{\text{CAL}} .45$ lb, 25 lb, 20 kg or 10 kg.
NOTE: Using a heavier calibration weight will increase scale accuracy.
5. Press UNIT. The display reads $\overline{\text{CAL}} 0$ lb ($\overline{\text{CAL}} 0$ kg).
6. Remove all weight from the scale.
NOTE: During calibration be sure vibration and air currents are not present.
7. Press FEED. The display will count down to zero. The counter will reset if too much vibration is present.
8. When the zero calibration is successful, the display reads $\overline{\text{CAL}} XX$ lb or kg, where XX is the span calibration weight selected above
9. Place the span calibration weight on the platform.
NOTE: to exit calibration without saving, press UNIT until the scale returns to the weigh mode.
10. Press FEED.
11. The display will count down. When calibration is complete, the scale will return to the weigh mode.

Multiple Point Calibration

Do not attempt to calibrate this scale without using calibrated test weights in the amounts stated below. The multiple point calibration sequence will result in the most accurate calibration possible. **CAUTION: Calibrating this scale improperly will void the warranty and will require field service or return of the scale to the factory.**

1. Turn the scale on by pressing the ON/OFF button.
2. Press and hold ZERO and REWEIGH simultaneously.
3. When the display reads $\overline{\text{CAL}}.45$ lb, release ZERO and REWEIGH.
4. Press and hold the FEED button until the display reads $\overline{\text{CAL}}.50$ lb.
5. To calibrate in kg, press the FEED button. The display will read $\overline{\text{CAL}}.50$ kg
6. Press UNIT and the display will read $\overline{\text{CAL}}.0$ lb ($\overline{\text{CAL}}.0$ kg)
7. Remove all weight from the scale.
NOTE: During calibration be sure vibration and air currents are not present.
8. Press FEED. The display will count down to zero. The counter will reset if too much vibration is present.
9. Once the zero calibration is successful, the display will read $\overline{\text{CAL}}.10$ lb ($\overline{\text{CAL}}.5$ kg).
10. Place 10 lb (5 kg) on the scale and press FEED.
11. When successful, the display will read $\overline{\text{CAL}}.20$ lb ($\overline{\text{CAL}}.10$ kg).
12. Place 20 lb (10 kg) on the scale and press FEED.
13. When successful, the display will read $\overline{\text{CAL}}.30$ lb ($\overline{\text{CAL}}.15$ kg).
14. Place 30 lb (15 kg) on the scale and press FEED.
15. When successful, the display will read $\overline{\text{CAL}}.40$ lb ($\overline{\text{CAL}}.20$ kg).
16. Place 40 lb (20 kg) on the scale and press FEED.
17. When successful, the scale will return to the weigh mode.

Calibration Troubleshooting

If $\overline{\text{ERR}}$ appears on the display during step 8, the calibration zero is out of range. Remove all weight from the platform and press FEED to perform the zero calibration again. If this error persists, consult the raw counts table below.

If $\overline{\text{ERR}}$ appears on the display during step 10, 12, 14 or 16, the span calibration is out of range. Place the proper weight on the platform and press FEED to perform the span calibration again. If this error persists, consult the raw counts table below.

To Access Raw Counts:

1. Press and hold ZERO and REWEIGH simultaneously.
2. When the display reads $\overline{\text{R.L.}}$ lb, release ZERO and REWEIGH.
3. Press UNIT until the RAW A/D count is displayed.
4. Apply test weights and compare results to the table below.
5. Press UNIT to exit.

The following table shows the acceptable Raw Counts for no load and each calibration point. If the scale's raw counts are not within the ranges specified in the following table, contact Doran's Technical Assistance department at tech@doranscales.com.

Two Point Calibration Troubleshooting

Calibration Requirements in Raw Counts	Minimum	Maximum
Zero Calibration Point	0	35,000
25 lb (10 kg)	28,290 (24,417)	68,210 (64,843)
45 lb (20 kg)	50,430 (48,834)	95,270 (94,686)

Multiple Point Calibration Troubleshooting

Calibration Requirements in Raw Counts	Minimum	Maximum
Zero Calibration Point	0	35,000
10 lb (5 kg)	9,840 (10,852)	49,760 (51,278)
20 lb (10 kg)	22,140 (24,417)	62,060 (64,843)
30 lb (15 kg)	31,980 (35,269)	76,820 (81,121)
40 lb (20 kg)	44,280 (48,834)	89,120 (94,686)

Section 4. Parameter Setup

The DS4500 offers the ability to change the shutoff timer settings. Parameter settings shown in bold are the default settings.

Entering and Exiting Setup Mode

To enter setup mode from the front panel, Press and hold ZERO and REWEIGH simultaneously. Release both buttons when the display reads **CAL.45**.

To exit the setup mode, press UNIT until the display returns to the weigh mode.

Setup Mode Navigation

1. Press UNIT to change the current parameter.
2. Press FEED to change the parameter setting.

Calibration Weight Selection

CAL	
25 (10 kg)	25 LB (10 kg)
45 (20 kg)	45 LB (20 kg)

Calibration Mode Selections

CAL	Zero Calibration Point
0	Press FEED to calibrate zero point <i>NOTE: This parameter is only visible when in the calibration mode.</i>

CAL	Span Calibration Point
25 (10kg)	25 LB(10kg)
45 (20kg)	45 LB(20kg) <i>NOTE: This parameter is only visible after a zero calibration is performed.</i>

Start Up Zero

500	
0n	Scale automatically zeros when the scale is turned on.
0F	Scale will not zero when the scale is turned on.

Automatic Shutoff Timer

R0	Automatic shutoff timer. The timer controls the period of time the scale stays on after non-use.
10	10 seconds
30	30 Seconds
60	1 minute
120	2 minutes
180	5 minutes
300	10 minutes
600	15 minutes
0F	Automatic shutoff timer disabled.

LB Units Enable / Disable

0n	Scale can read lb units
0FF	Scale can not read lb units

lb:oz Units Enable / Disable

0n	Scale can read lb:oz units
0FF	Scale can not read lb:oz units

KG Units Enable / Disable

0n	Scale can read kg units
0FF	Scale can not read kg units

OZ Units Enable / Disable

0n	Scale can read oz units
0FF	Scale can not read oz units

Grams Units Enable / Disable

0n	Scale can read g units
0FF	Scale can not read g units

Raw Counts

#####	Raw counts from A/D converter
	View these numbers if calibration is unsuccessful. Refer to Section 3 for interpretation of these numbers. Press KG to exit setup mode.

Section 5. Data Communications

The DS4500 is equipped with a USB mini communications port. Data will be transmitted when a patients weight is held on the display. The hold annunciator will be active when a held weight is achieved.

The USB port is located at the rear of the scale. To receive data output from the scale, connect any USB cable with a USB mini connector to your PC. It may be necessary to install the proper USB drivers on your PC.

Doran Protocol		
Command (RXD) Computer to Scale	Scale Output Responds (TXD) Scale to Computer	Description
Z or z		Zero the scale (if in motion, scale will wait until stable, then zero)
<cr> or W	<stx><weight><sp> <uu><cr><lf> Or in Feed Operation: <stx><weight><sp> <uu><sp><feed> <cr><lf>	<stx> (☉) = ASCII 02, Start of Text <weight> = 6 character field with decimal point <sp> () = ASCII 20h, Space <uu> = 5 character field "lb", "oz", "lb:oz", "kg", "g". Leading spaces for empty characters. <feed> = 11 character field. "BEFORE FEED", "AFTER FEED" or "AMOUNT FED". Leading spaces for empty characters. <cr> (↵) = ASCII 0D, Carriage Return <lf> (▣) = ASCII 0A, Linefeed
U		Scale scrolls through available weight units
R or r		Scale performs a Reweigh operation

Section 6. Specifications

Scale Dimensions	25" L x 13.75" W x 3.75" H
Power	4 AA Alkaline Batteries AC Adapter One year battery life with 10 second Automatic Shutoff Timer setting.
Displayed Units	lb, lb:oz, oz, kg, g
Capacity	45 lb x 0.005 lb 20 kg x 0.002 kg 20,000 g x 2 g 720 oz x 0.1 oz 45 lb:oz x 0.1 oz
Construction	ABS Plastic Housing
Options	Carrying Case AC Adapter

Section 7. Troubleshooting

General Problem Resolution

Problem	What to Do or Check
Weight reading will not repeat or scale does not return to zero when weight is removed.	Person or object other than that being weighed is touching the scale. Verify that there is nothing caught in the feet area or interfering with the feet.
Scale overloads before scale capacity is reached.	Verify scale calibration is correct. If problem persists, recalibrate the scale.
Scale will not come to zero when the ZERO button is pressed.	Make sure that the scale is stabilizing. After pressing the ZERO button, the scale should zero as soon as it becomes stable.
Weight readings are not correct.	Verify the scale calibration with an accurate test weight. If the readings are not correct, recalibrate. Be sure the platform is on a flat surface and all four feet are touching the surface.
Scale drifts off zero.	Check for air currents and/or vibration around the scale.
Scale shuts itself off or will not turn on.	Press the On/Off button to turn on the indicator. Check that new batteries are installed properly in the battery tray.

Error Messages

Error Message	What to Do or Check
Err EP	<p>The setup parameters loaded in nonvolatile memory have become corrupted.</p> <p>If this problem persists, contact Doran Technical Support for assistance.</p>
Err Ad	<p>The A/D communication is not detected. Ensure the wire harness was not pinched during assembly.</p> <p>If this problem persists, contact Doran Technical Support for assistance.</p>
Err 0	<p>The calibration zero is out of range. Error is displayed after a zero calibration attempt.</p> <p>Refer to the Calibration Troubleshooting section for additional information. If this problem persists, contact Doran Technical Support for assistance.</p>
Err SP	<p>The span calibration is out of range. Error is displayed after a span calibration attempt.</p> <p>Refer to the Calibration Troubleshooting section for additional information. If this problem persists, contact Doran Technical Support for assistance.</p>
ou Ld	<p>The scale is in overload. The load on the scale platform exceeds the scale capacity by more than 105%.</p> <p>Remove excess weight from scale platform. If problem persists, recalibrate. If this problem still persists, contact Doran Technical Support for assistance.</p>
95 ol	<p>The scale is in an extreme overload condition. The load on the scale platform exceeds the scale capacity by more than 150%.</p> <p>Immediately remove excess weight from scale platform as damage not covered under the warranty can occur. If problem persists, recalibrate. If this problem still persists, contact Doran Technical Support for assistance.</p>

**Doran Scales, Inc.
883 Enterprise Court
St. Charles, IL 60174**

www.doranscales.com

tech@doranscales.com